

TIG Torch, Cable & Connector

Index of Torches

Part Numbers

Index of Torches

Part Numbers

Index of Torches

Part Numbers

Index of Torches

Part Numbers

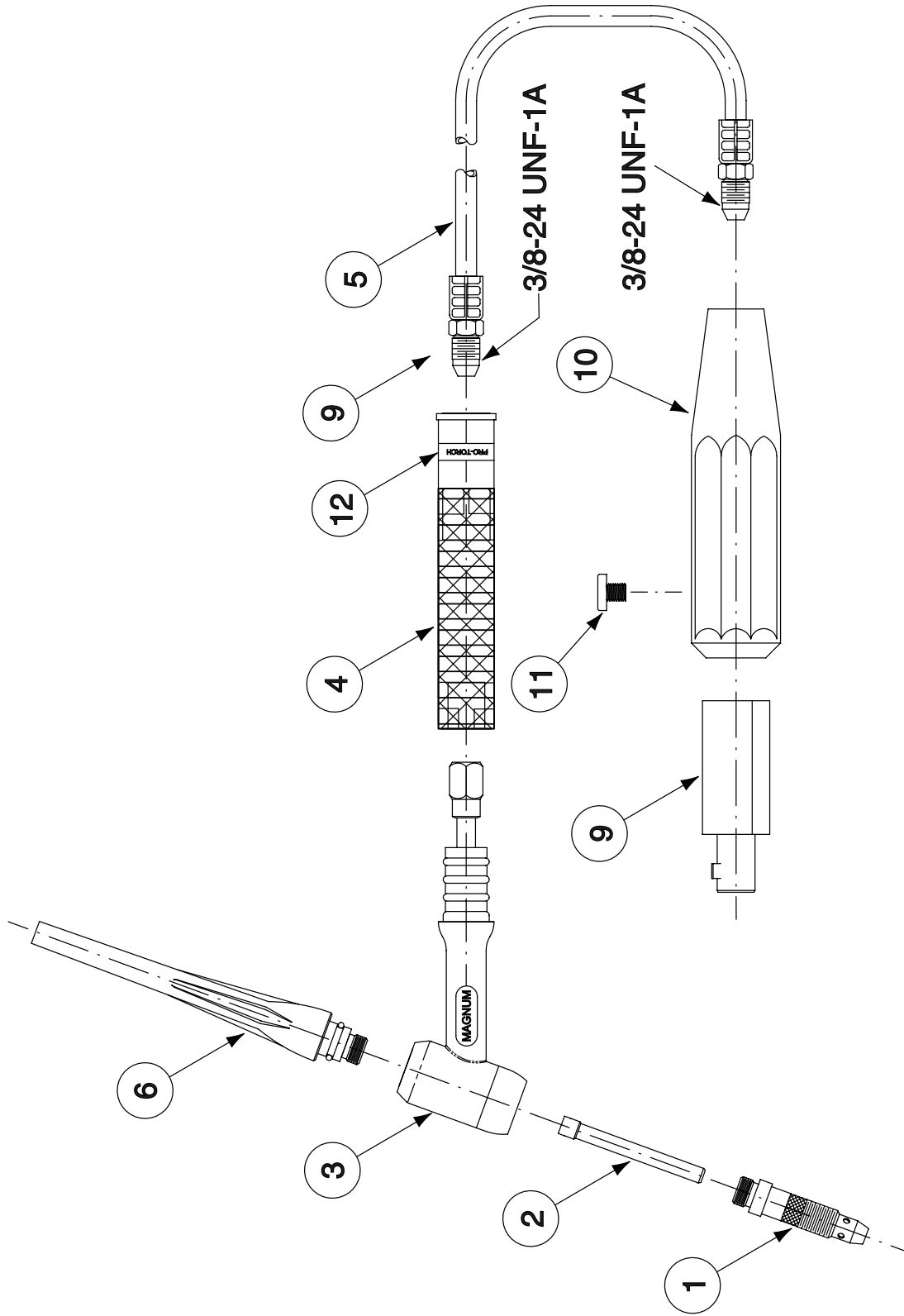

Indicates a change this printing.

Use only the parts marked "x" in the column under the heading number called for in the model index page.

ITEM	DESCRIPTION	PART NO.	QTY.	1	2	3	4	5	6	7	8	9
1	3/32" Collet Body	S19500-4	1	X								
2	3/32" Collet	S19498-4	1	X								
3	Torch Body	S19259-1	1	X								
4	Torch Handle	S19511-1	1	X								
5	Ultra-Flex Power & Gas Cable 12.5 Ft	S25811-1	1	X								
6	Back Cap (Long)	S19514-1	1	X								
7	Tungsten Electrode (Not Shown)	S22528-1	1	X								
8	Alumina Nozzle #7 (Not Shown)	S19367-3	1	X								
9	TIG Connector Body	S25221-1	1	X								
10	Insulating Boot	S25223-1	1	X								
11	Boot Plug	S25224-1	1	X								
12	Decal	S24942	1	X								

#



Index of Torches
 Sub Assembly Illustration
 Index of Torches
 Sub Assembly Illustration
 Index of Torches
 Sub Assembly Illustration
 Index of Torches
 Sub Assembly Illustration